

**Accordion Doors
& Partitions**

Soundmaster[®]
Modernfold[®]



Accordion Doors and Partitions from Modernfold.

When you need to get the most from your space.

Accordion doors and partitions from Modernfold are designed to provide quick and easy space division with moderate sound attenuation and a pleasing visual appearance.

All Modernfold accordion doors and partitions provide quick sight and sound division with a simple pull-and-latch operation. Electric operation is also available.

Accordion doors and partitions are available as single and paired openings. For optimal

design flexibility, curved track allows the partition to move around corners.

Modernfold offers a large selection of standard finishes.

Since Modernfold's inception, building owners, facility managers, architects, interior designers, and contractors have come to recognize the Modernfold name—a name synonymous with flexible space design, quality products, professional installation, and ongoing product support.



Soundmaster®

For versatility and durability, Modernfold's Soundmaster offers a broad range of vinyl, carpet, and fabric choices to complement any room decor. Its steel sound liner and three-ply top and bottom sweeps provide moderate speech privacy.



Modernfold®

Modernfold accordion doors and partitions are the industry standard. With their durability, replaceable outer coverings and

easy operation, they are designed to give you many years of easy and trouble free operation.



Soundmaster accordion partitions are ideal for dividing space economically when moderate sound attenuation is desired.

Soundmaster accordion partitions are ideal for applications in church classrooms, fellowship halls, clinics, restaurants, and many other applications. Behind its fabric outer covering, Soundmaster has steel paneled sound liners to provide moderate sound attenuation and increased durability.

Optional electric operation makes large, even curved openings as easy as turning a key. When both durability and moderate noise reduction are important, Soundmaster partitions are the answer.

Acoustical Performance – up to 40 STC is provided with Soundmaster's steel panel and

membrane liners. Three-ply top and bottom sweeps assure a positive seal. Long-term strength and durability is made possible by Soundmaster's patented, three-dimensional welded steel frame and heavy duty construction.



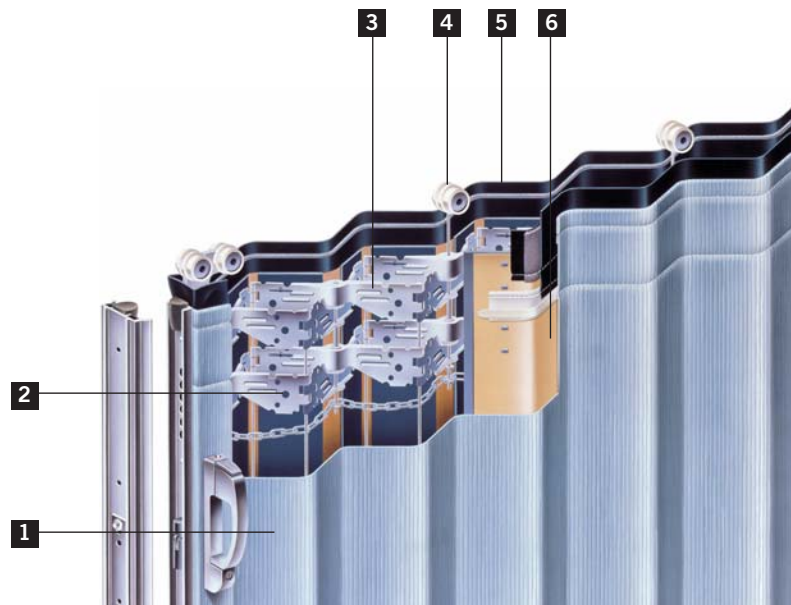

1 Easily replaceable Class A rated coverings

4 Ball bearing trolleys with high tensile yokes

2 Continuous horizontal pantograph hinges

5 Three-ply top and bottom sweep seals

3 Three dimensional welded steel frame

6 Steel sound liner



The Modernfold accordion is ideal for basic sight and space separation.

When strength and durability are important and only sight division is required, Modernfold accordion doors and partitions are the answer. Modernfold partitions feature a durable steel frame

construction, ball bearing trolleys, and a wide choice of finish options. The heavy, all steel frame and hinging, which supports the finish, takes a lot of abuse yet its weight requires only

minimal support. In addition to simple, straight "wall-to-wall" runs, Modernfold accordion partitions can be curved or even serpentine to meet your exact needs.

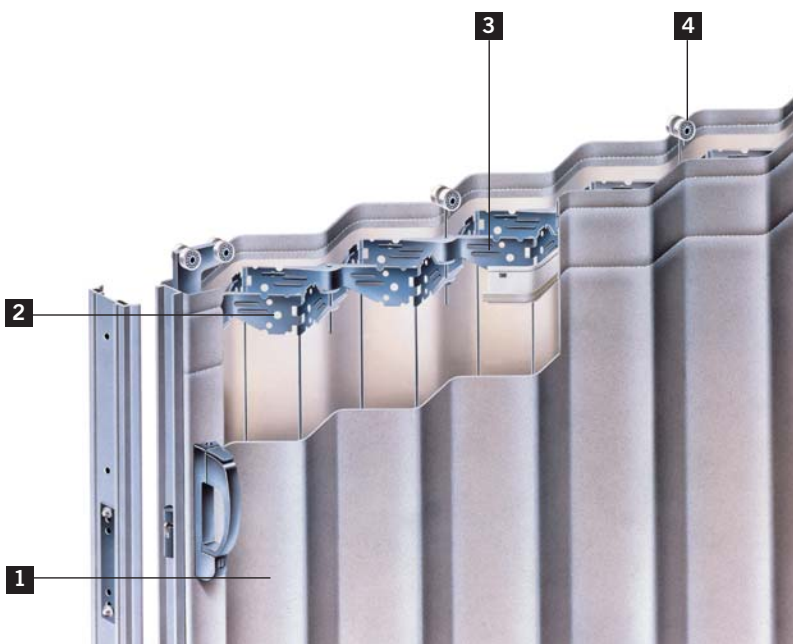

- 1** Easily replaceable Class A rated coverings
- 2** Continuous horizontal pantograph hinges
- 3** Three dimensional welded steel frame
- 4** Ball bearing trolleys with high tensile yokes

Accordion Door/Partitions Selector Guide

* Per lineal foot of opening width, plus posts.
 ** Paired partitions double maximum width

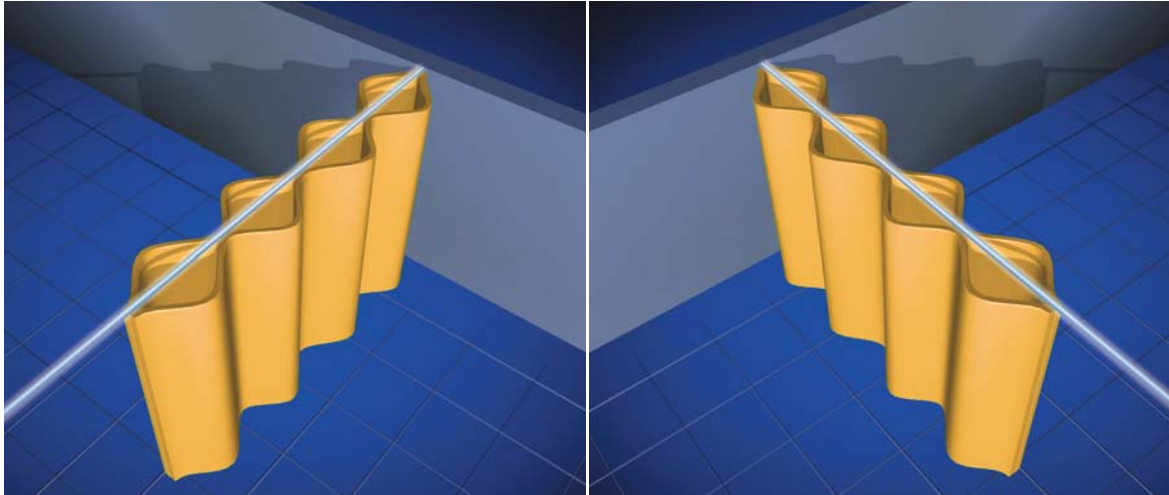

	Soundmaster				Modernfold			
Model	8M	8E	12M	12E	800M	800E	1200M	1200E
Stack Width	9-inch	9-inch	12-5/8 inch	12-5/8 inch	9-inch	9-inch	12-5/8 inch	12-5/8 inch
Stack Depth*	2-1/8 inch	2-1/8 inch	1-3/4 inch	1-3/4 inch	2-1/8 inch	2-1/8 inch	1-3/4 inch	1-3/4 inch
Operation	Manual	Electric	Manual	Electric	Manual	Electric	Manual	Electric
Frame	All Steel	All Steel	All Steel	All Steel	All Steel	All Steel	All Steel	All Steel
Skin/Face Options	Vinyl, Fabric, Carpet	Vinyl, Fabric, Carpet	Vinyl, Fabric, Carpet	Vinyl, Fabric, Carpet	Vinyl, Fabric, Carpet	Vinyl, Fabric, Carpet	Vinyl, Fabric, Carpet	Vinyl, Fabric, Carpet
	#7 Steel Track	#7 with Chain Guide	#7 Steel Track	#7 with Chain Guide	#7 Steel Track	#7 with Chain Guide	#7 Steel Track	#7 with Chain Guide
Suspension Options	#6 Steel Track	—	#6 Steel Track	—	#6 Steel Track	—	#6 Steel Track	—
	#5 Aluminum Track	—	—	—	#5 Aluminum Track	—	—	—
Hinge Type	All Steel	All Steel	All Steel	All Steel	All Steel	All Steel	All Steel	All Steel
Maximum Width**	50'-0"	50'-0"	60'-0"	60'-0"	50'-0"	50'-0"	60'-0"	60'-0"
Maximum Height	16'-0"	16'-0"	16'-0"	16'-0"	16'-0"	16'-0"	16'-0"	16'-0"
STC	39	39	40	40	N/A	N/A	N/A	N/A
Hanging Weight	4-1/4 lb/sq ft	4-1/4 lb/sq ft	5-lb/sq ft	5-lb/sq ft	2-lb/sq ft	2-lb/sq ft	2-3/4 lb/sq ft	2-3/4 lb/sq ft

Manufacturer reserves the right to change or modify product or specifications at any time without prior notice. Soundmaster® and Modernfold® are registered trademarks of Modernfold, Inc.

SOUNDMASTER® & MODERNFOLD® TECHNICAL DATA

This specification along with product information and model details can be downloaded from www.modernfold.com

SPECIFICATION - SECTION 08 35 13 ACCORDION FOLDING DOORS

PART 1 - GENERAL

1.1 RELATED DOCUMENTS

- A. Drawings and general provisions of the Contract including General and Supplementary Conditions and Division 01 Specification Sections, apply to this Section.

1.2 SUMMARY

- A. This Section includes the following:
1. Furnish and install accordion folding partitions as indicated in drawings.
- B. Related Sections include the following:
1. Division 03 Sections for concrete tolerances required.
 2. Division 05 Sections for primary structural support, including pre-punching of support members by structural steel supplier per partition supplier's template.
 3. Division 06 Sections for wood framing and supports, and all blocking at head and jambs as required.
 4. Division 09 Sections for wall and ceiling framing at head and jambs.

1.3 QUALITY ASSURANCE

- A. Installer Qualifications: An experienced installer who is certified in writing by the partition manufacturer, as qualified to install the manufacturer's partition systems for work similar in material, design, and extent to that indicated for this Project.
- B. Preparation of the opening shall conform to the dimensions specified, plumb, level, and in accordance to building practices.
- C. Acoustical Performance: Test partitions in an independent acoustical laboratory in accordance with ASTM E90 to attain no less than the STC rating specified. Provide a complete and unedited written test report by the testing laboratory upon request.

1.4 SUBMITTALS

- A. Product Data: Material descriptions, construction details, finishes, installation details, and operating instructions for each type of partition, component, and accessory specified.
- B. Shop Drawings: Show location and extent of partitions. Include plans, elevations, sections, details, attachments to other construction, and accessories. Indicate dimensions, weights, conditions at openings, and at storage areas, and required installation, storage, and operating clearances. Indicate location and installation

requirements for hardware and track, including floor tolerances required and direction of travel. Indicate blocking to be provided by others.

- C. Setting Drawings: Show imbedded items and cutouts required in other work, including support beam punching template.
- D. Samples: Color samples demonstrating full range of finishes available by architect. Verification samples will be available in same thickness and material indicated for the work.

1.5 DELIVERY, STORAGE, AND HANDLING

- A. Clearly mark packages and partitions with numbering systems used on Shop Drawings. Do not use permanent markings on partitions.
- B. Protect partitions during delivery, storage, and handling to comply with manufacturer's direction and as required to prevent damage.

1.6 WARRANTY

- A. Provide written warranty by manufacturer of partitions agreeing to repair or replace any components with manufacturing defects.
- B. Warranty period: Two (2) years.

PART 2 – PRODUCTS (SOUNDMASTER)

2.1 MANUFACTURERS, PRODUCTS, AND OPERATION

- A. Manufacturers: Subject to compliance with requirements, provide product by the following:
1. Modernfold, Inc.
- B. Products: Subject to compliance with the requirements, provide the following product:
1. Soundmaster #8 Accordion Folding Partition.
 2. Soundmaster #12 Accordion Folding Partition.

2.2 OPERATION

- A. Soundmaster #8: Manually operated, top supported, accordion folding.
- B. Soundmaster #12: Manually operated, top supported, accordion folding.

2.3 CONSTRUCTION

- A. Shall consist of steel hinge plates welded to 3/16-inch (5mm) diameter vertical steel rods, with a single row of plates at the bottom and top with intermediate rows at

SOUNDMASTER® & MODERNFOLD® TECHNICAL DATA

approximately 42-inch (1067mm) on center. Partitions 10'-0" (3048mm) high or over have a double row of hinge plates at the top. A high tensile alloy steel trolley yoke, functioning as a hinge pin at required intervals, supports the frame assembly.

2.4 PARTITION FINISHES

- A. Finish: Factory applied, Class "A" rated material. Finish shall be (select as appropriate):
1. Reinforced heavy duty vinyl with woven backing weighing not less than 27 ounces per lineal yard.
 2. Acoustical, non-woven needle punch carpet, with fused fibers to prevent unraveling or fray of material.
 3. Wall covering and upholstery fabric with surface treatment to resist stains.
 4. Customer's own material (subject to factory approval).
- B. Partition Trim: Exposed sweep strips of one consistent color (Smoke Gray or Dark Bronze).

2.5 SOUND SEALS

- A. Shall be pairs of three-layer flexible sweep strips at top and bottom. Vertical female sound channel shall be polyurethane foam lined.
- B. Sound Insulation: 24-gage, V-grooved steel panels and heavy duty flame resistant acoustical membrane. Each panel attaches to the frame with steel leaf fasteners.
- C. Pairs of Flexible Sweep Strips: Shall be provided at top and bottom of the partition. Air release for air trapped within the folding partition shall be accomplished during operation by a series of 3/8-inch (9.5mm) diameter holes through the lead post molding.

2.6 HARDWARE

- A. Grip type hand pulls shall be die cast zinc, satin chrome finish. Extruded aluminum or plastic hand pulls will not be accepted.

2.7 SUSPENSION SYSTEM

- A. #5 (Soundmaster 8 only), #6, or #7 Suspension System, track and trolley sizes matched to the size of the partition.
1. Suspension Tracks: Shall be of a continuous "C" channel shaped track, connected to the structural support.
 2. Carriers: The accordion folding partition shall be suspended from the track by two-wheel intermediate and four-wheel lead trolley assemblies.

2.8 OPTIONS

- A. Electrical Operation: Electrically operated Soundmaster 8 and Soundmaster 12 shall be operated in 11-gage steel track with flanged steel ball bearing trolleys. Drive

mechanism shall be roller chain type. All auxillary equipment for electrical operation including track with integral chain guides, roller chain, drive unit and motor key operated control, overload safety device, and drive sprocket assemblies shall be supplied by partition manufacturer. Power supply circuits, wiring, and electrical connection shall be work by the electrical contractor.

B. Jamb-Lock: Backpost to be secured to the wall by the "Jamb-Lock" mechanism concealed within the backpost to provide a quick means of releasing and reattaching the partition for cleaning and decorative purposes.

C. Locks: Satin chrome handpulls with (select) manufacturer's standard locks or master-keyed locks. Master-keyed cylinders furnished by others. Locks shall be an integral part of the pull; Manually Operated Partitions Only.

PART 2 – PRODUCTS (MODERNFOLD)

2.1 MANUFACTURERS, PRODUCTS, AND OPERATION

- A. Manufacturers: Subject to compliance with requirements, provide product by the following:
1. Modernfold, Inc.
- B. Products: Subject to compliance with the requirements, provide the following product:
1. Modernfold #800 Accordion Folding Partition.
 2. Modernfold #1200 Accordion Folding Partition.

2.2 OPERATION

- A. Modernfold #800: Manually operated, top supported, accordion folding.
- B. Soundmaster #1200: Manually operated, top supported, accordion folding.

2.3 CONSTRUCTION

- A. Shall consist of steel hinge plates welded to 3/16-inch (5mm) diameter vertical steel rods, with a single row of plates at the bottom and top with intermediate rows at approximately 42-inch (1067mm) on center. Partitions 13'-0" (3048mm) high or over have a double row of hinge plates at the top. A high tensile alloy steel trolley yoke, functioning as a hinge pin at required intervals, supports the frame assembly.

2.4 PARTITION FINISHES

- A. Finish: Factory applied, Class "A" rated material. Finish shall be (select as appropriate):
1. Reinforced heavy duty vinyl with woven backing weighing not less than 27 ounces per lineal yard.

SOUNDMASTER® & MODERNFOLD® TECHNICAL DATA

2. Acoustical, non-woven needle punch carpet, with fused fibers to prevent unraveling or fray of material.
 3. Wall covering and upholstery fabric with surface treatment to resist stains.
 4. Customer's own material (subject to factory approval).
- B. Partition Trim: Exposed sweep strips of one consistent color (Smoke Gray or Dark Bronze).

2.5 HARDWARE

- A. Grip type hand pulls shall be die cast zinc, satin chrome finish. Extruded aluminum or plastic hand pulls will not be accepted.

2.6 SUSPENSION SYSTEM

- A. #5 (Modernfold 800 only), #6, or #7 Suspension System, track and trolley sizes matched to the size of the partition.
1. Suspension Tracks: Shall be of a continuous "C" channel shaped track, connected to the structural support.
 2. Carriers: The accordion folding partition shall be suspended from the track by two-wheel intermediate and four-wheel lead trolley assemblies.

2.7 OPTIONS

- A. Electrical Operation: Electrically operated Modernfold 800 and Modernfold 1200 shall be operated in 11-gage steel track with flanged steel ball bearing trolleys. Drive mechanism shall be roller chain type. All auxiliary equipment for electrical operation including track with integral chain guides, roller chain, drive unit and motor key operated control, overload safety device, and drive sprocket assemblies shall be supplied by partition manufacturer. Power supply circuits, wiring, and electrical connection shall be work by the electrical contractor.
- B. Pairs of Flexible Sweep Strips: Shall be provided at top and bottom of the partition. Air release for air trapped within the folding partition shall be accomplished during operation by a series of 3/8-inch (9.5mm) diameter holes through the lead post molding.
- C. Jamb-Lock: Backpost to be secured to the wall by the "Jamb-Lock" mechanism concealed within the backpost to provide a quick means of releasing and reattaching the partition for cleaning and decorative purposes.

- D. Locks: Satin chrome handpulls with (select) manufacturer's standard locks or master-keyed locks. Master-keyed cylinders furnished by others. Locks shall be an integral part of the pull; Manually Operated Partitions Only.

PART 3 – EXECUTION

3.1 INSTALLATION

- A. General: Comply with partition manufacturer's written installation instructions, Drawings, and approved Shop Drawings.
- B. Install partitions and accessories after other finishing operations, including painting have been completed.
- C. Defective partitions are not acceptable.

3.2 CLEANING AND PROTECTION

- A. Clean partition surfaces upon completing installation of partitions to remove dust, dirt, adhesives, and other foreign materials according to manufacturer's written instructions.
- B. Provide final protection and maintain conditions in a manner acceptable to the manufacturer and installer that insure operable partitions are without damage or deterioration at time of Substantial Completion.

3.3 ADJUSTING

- A. Adjust partitions to operate smoothly, easily, and quietly throughout entire operational range. Lubricate hardware and other moving parts.

3.4 EXAMINATION

- A. Examine flooring, structural support, and opening, with Installer present, for compliance with requirements for installation tolerances and other conditions affecting performance of partitions. Proceed with installation only after unsatisfactory conditions have been corrected.

3.5 DEMONSTRATION

- A. Demonstrate proper operation and maintenance procedures to Owner's representative.
- B. Provide Operation and Maintenance Manual to Owner's representative.

SOUNDMASTER® & MODERNFOLD® TECHNICAL DATA — OPTIONS

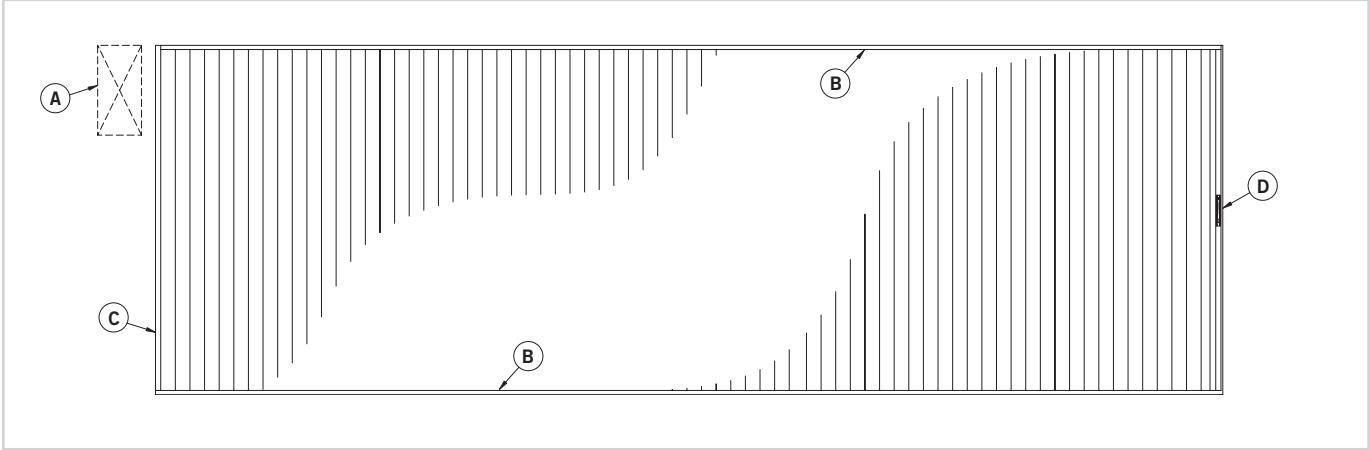

SOUNDMASTER® & MODERNFOLD® TECHNICAL DATA TYPICAL STACK CONFIGURATIONS

Soundmaster 8 & Modernfold 800 Standard Opening

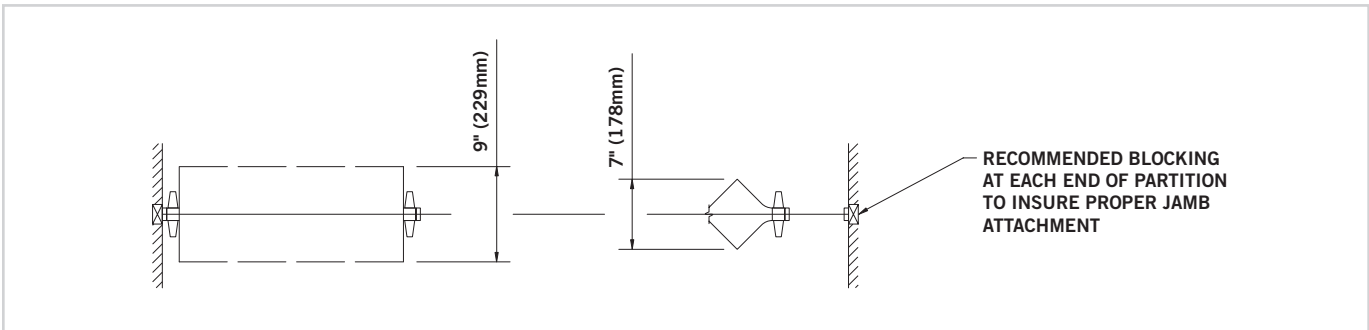

Soundmaster 8 & Modernfold 800
Sliding Panel Storage Pocket

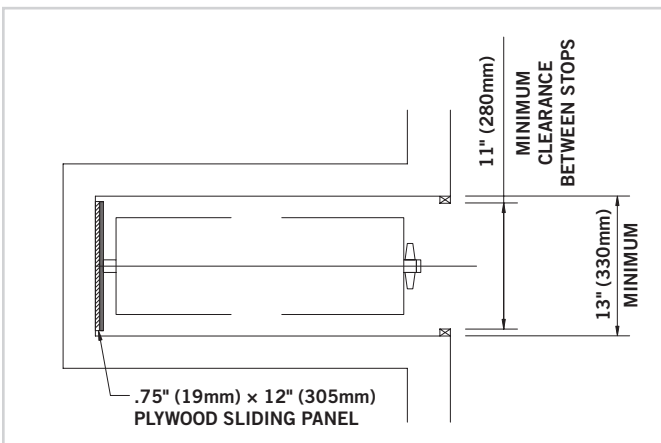

Soundmaster 8 & Modernfold 800
Rolling Post Storage Pocket

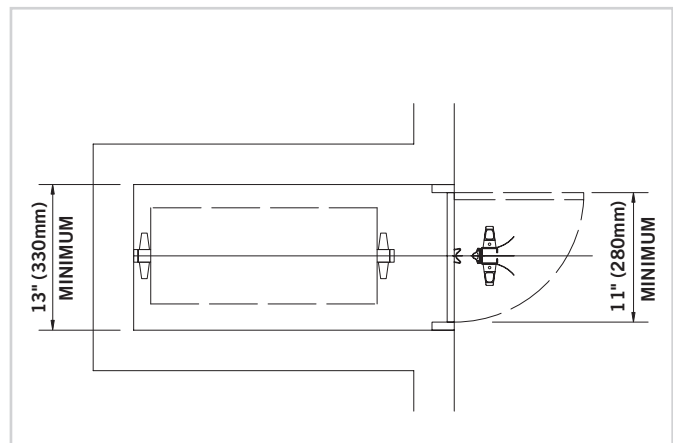

SOUNDMASTER® & MODERNFOLD® TECHNICAL DATA TYPICAL STACK CONFIGURATIONS

Soundmaster 12 & Modernfold 1200 Standard Opening

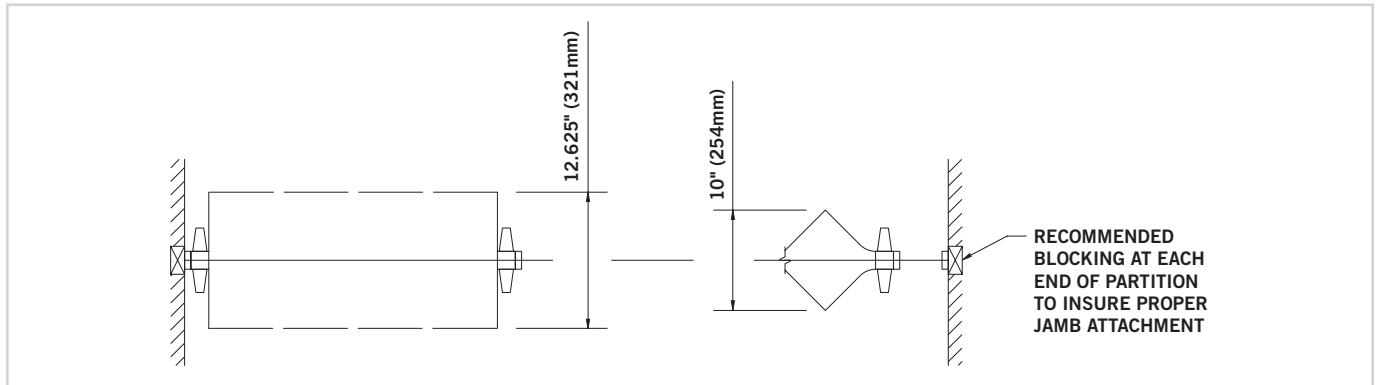

Soundmaster 12 & Modernfold 1200 Sliding Panel Storage Pocket

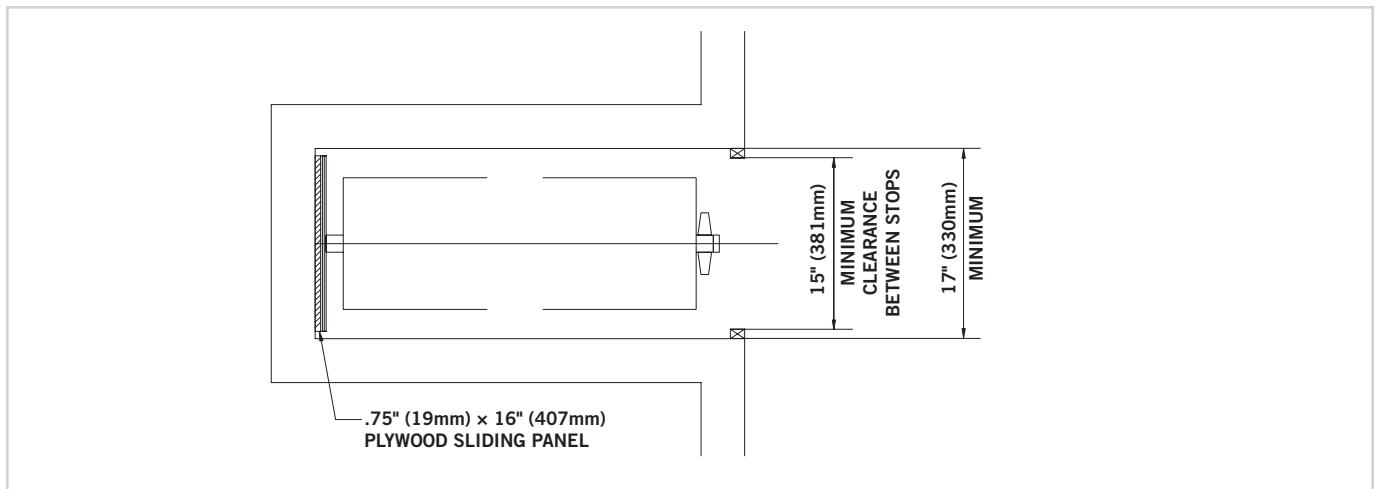

Soundmaster 12 & Modernfold 1200 Rolling Post Storage Pocket

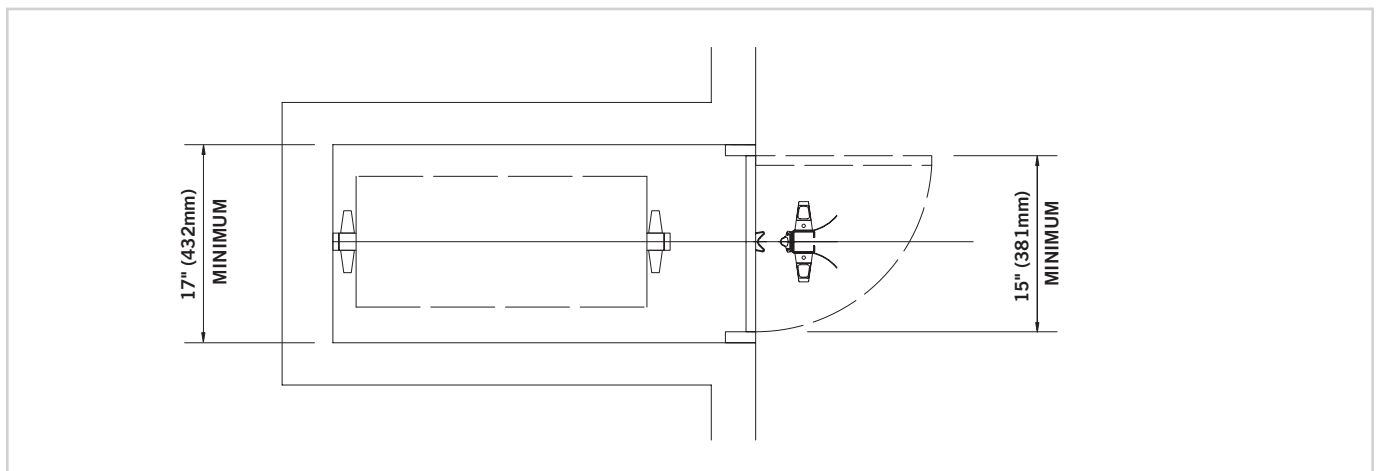

SOUNDMASTER® & MODERNFOLD® TECHNICAL DATA — HEAD DETAILS

Head Details with #5 Track for Partitions to 33'-2" Wide x 12'-0" (13'-0" for Modernfold 800) Max. Height (66'-4" Wide if a Pair)

Soundmaster 8 & Modernfold 800
#5 Track in Wood Cased Beam

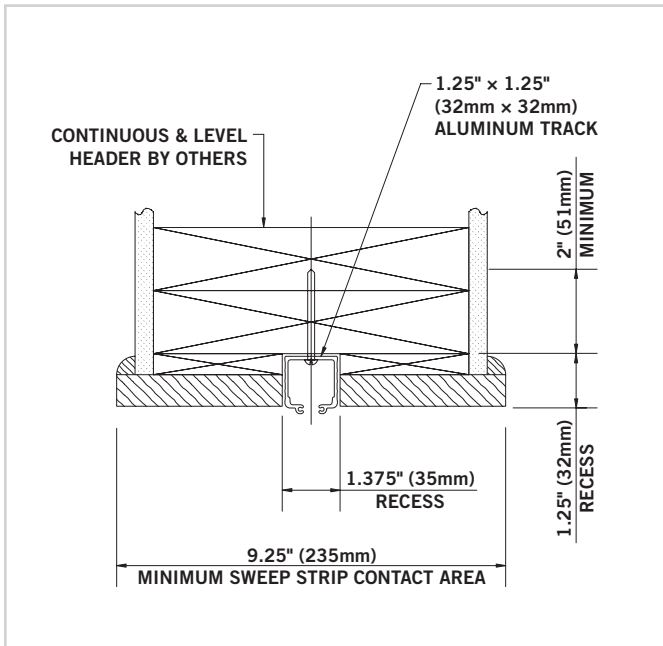

Soundmaster 8 & Modernfold 800
#5 Track Recessed (w/Ceiling Guard/Sub-Channel)

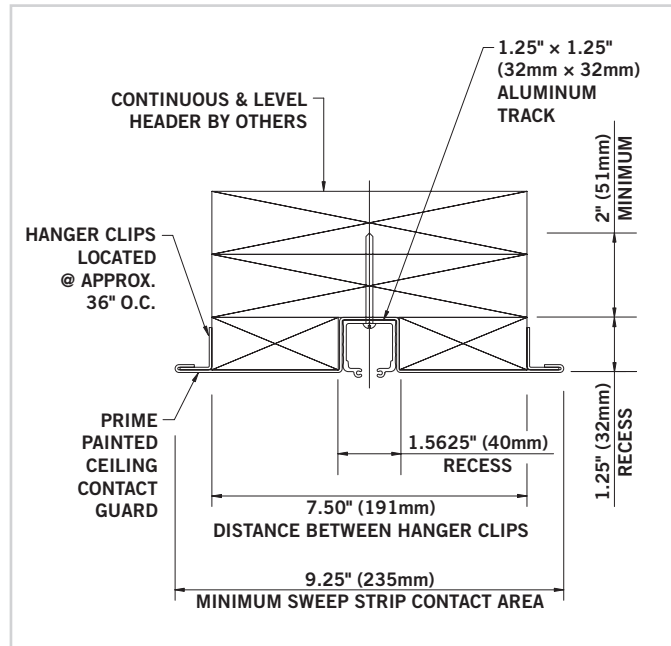

Soundmaster 8 & Modernfold 800
#5 Track Surface Mounted

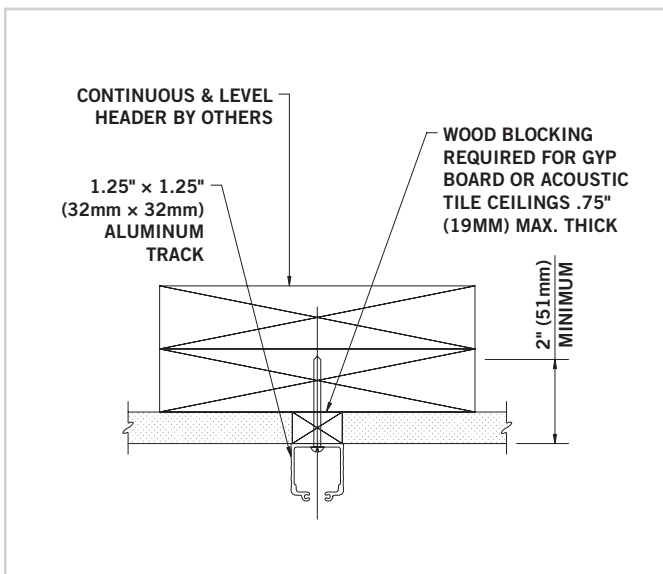

Soundmaster 8 & Modernfold 800
#5C Track Recessed

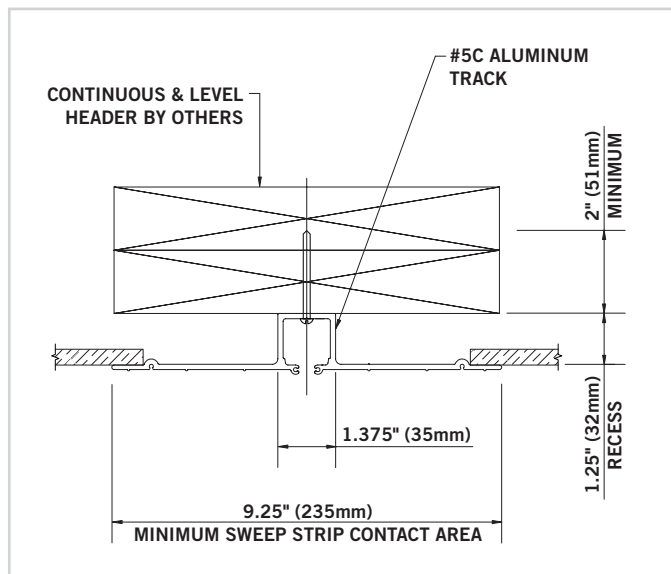

SOUNDMASTER® & MODERNFOLD® TECHNICAL DATA — HEAD DETAILS

Head Details with #6 Track for Partitions over 33'-2" Wide x 14'-0" Max. Height (66'-4" Wide if a Pair)

Soundmaster 8 & Modernfold 800
#6 Track in Wood Cased Beam

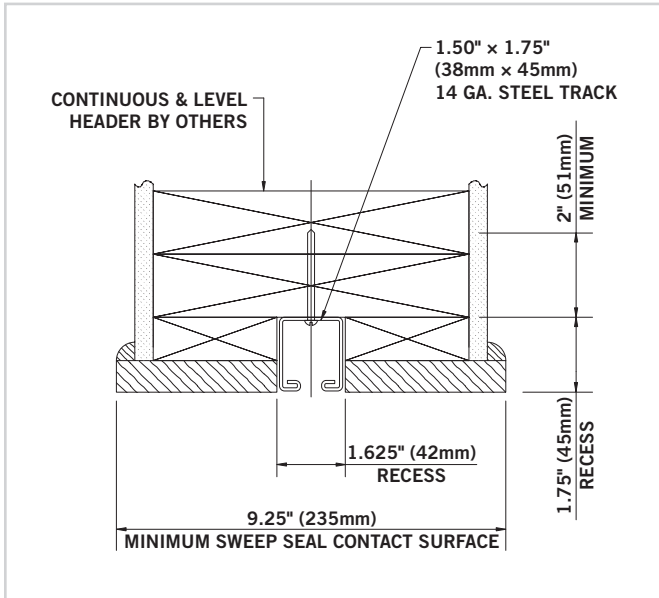

Soundmaster 8 & Modernfold 800
#6 Track Recessed (w/Ceiling Guard)

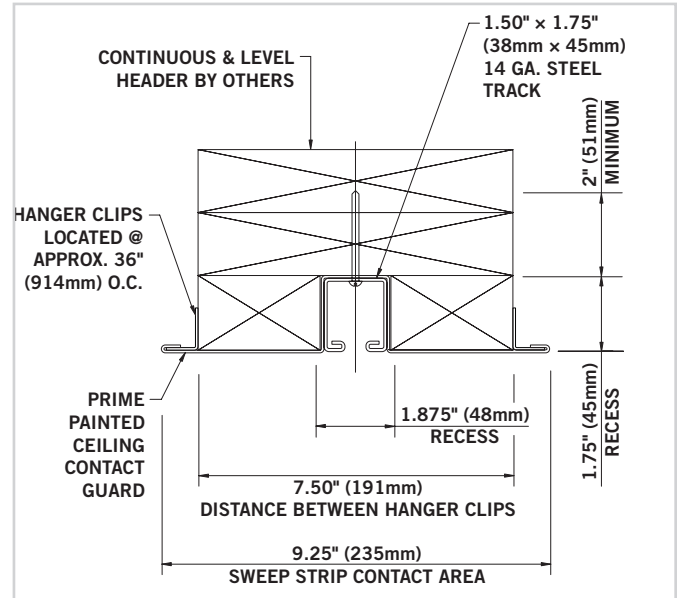

Head Details with #7 Track for Partitions over 14'-0" up to 16'-0" Max. Height

Soundmaster 8 & Modernfold 800
#7 Track in Wood Cased Beam

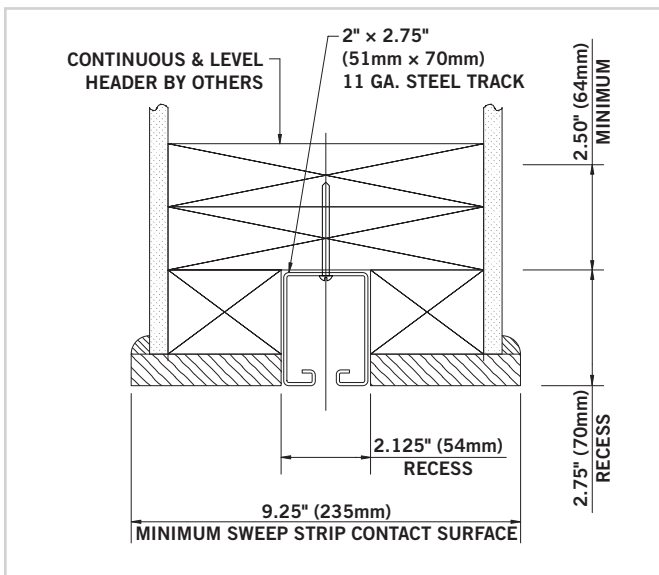

Soundmaster 8 & Modernfold 800
#7 Track Recessed (w/Ceiling Guard)

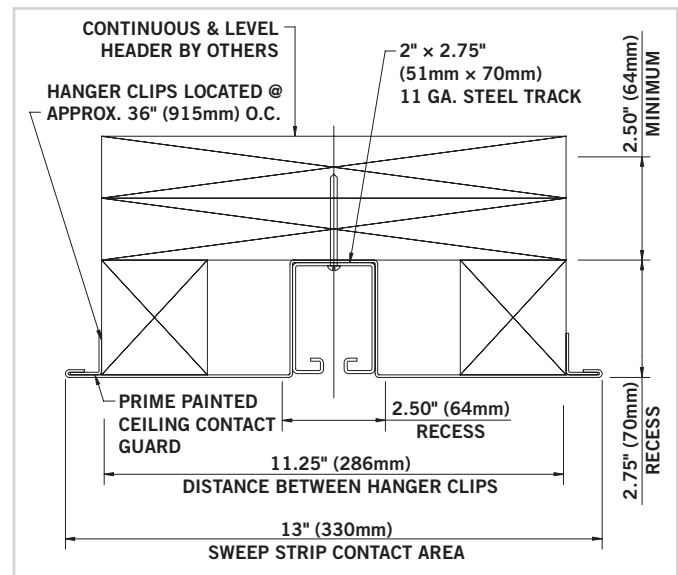

NOTE: Electrical operation required for openings over 400 sq ft (37.2 sq m) for Soundmaster 8 and 360 sq ft (33.444 sq m) for Soundmaster 12.

SOUNDMASTER® & MODERNFOLD® TECHNICAL DATA — HEAD DETAILS

Head Detail with #7 Chain Guide Track for Soundmaster Openings over 400 sq ft (37.2 sq m)

Soundmaster 8 & Modernfold 800 #7 Track Electrically Operated

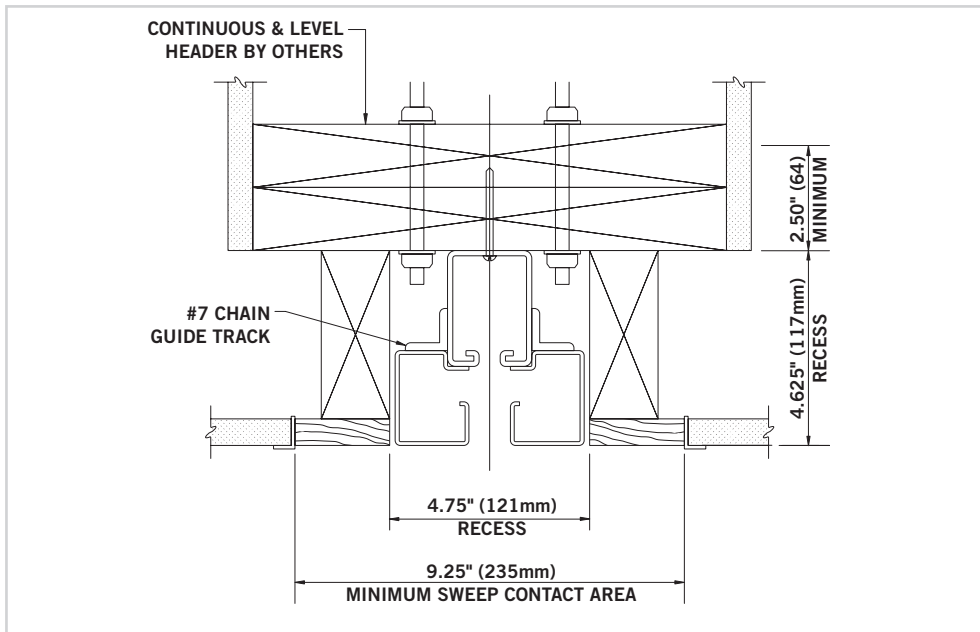

Head Details with #6 Track — for Soundmaster Partitions to 30'-0" Wide x 12'-0" Max. Height (60'-0" Wide if a Pair) — for Modernfold Partitions to 40'-1" Wide x 14'-0" Max. Height (80'-2" Wide if a Pair)

Soundmaster 12 & Modernfold 1200 #6 Track in Wood Cased Beam

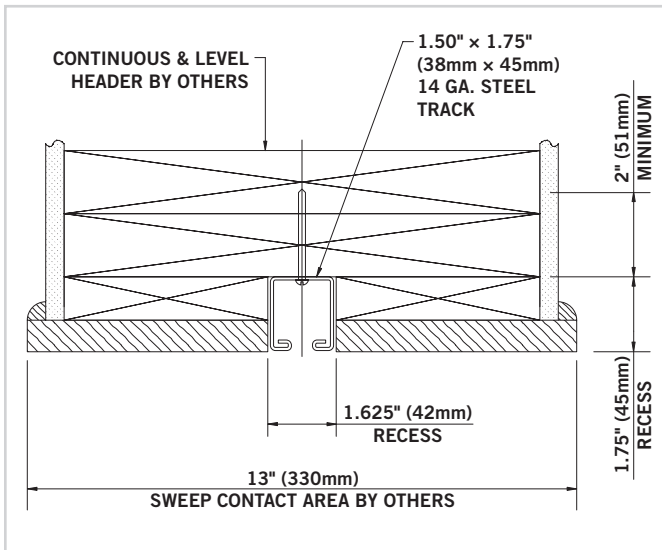

Soundmaster 12 & Modernfold 1200 #6 Track Recessed (w/Ceiling Guard)

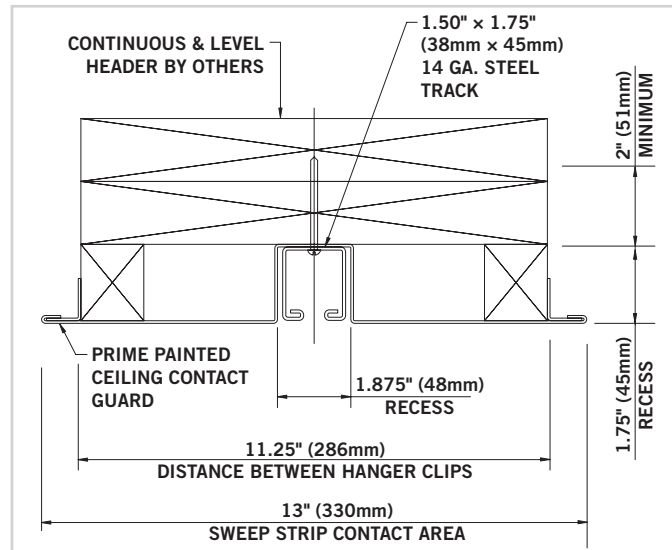

NOTE: Electrical operation required for openings over 400 sq ft (37.2 sq m) for Soundmaster 8, 360 sq ft (33.444 sq m) for Soundmaster 12, and 730 sq ft (67.89 sq m) for Modernfold 1200.

SOUNDMASTER® & MODERNFOLD® TECHNICAL DATA — HEAD DETAILS

Head Details with #7 Track — for Soundmaster Partitions over 12'-0" up to 16'-0" Max. Height
— for Modernfold Partitions over 14'-0" High up to 16'-0" High

Soundmaster 12 & Modernfold 1200
#7 Track in Wood Cased Beam

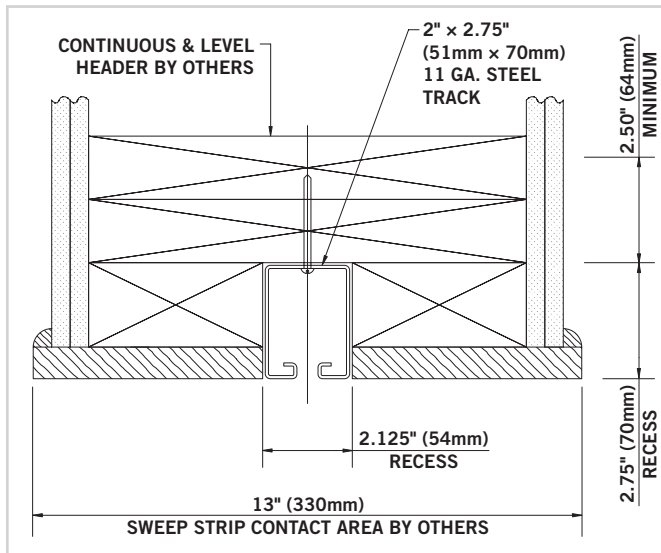

Modernfold 1200 #7 Track Recessed
(w/Ceiling Guard)

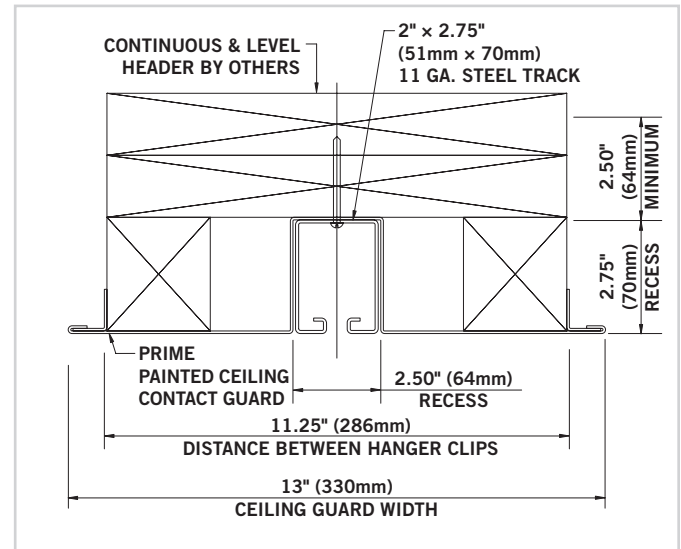

Soundmaster 12 #7 Track Recessed (w/Ceiling Guard)

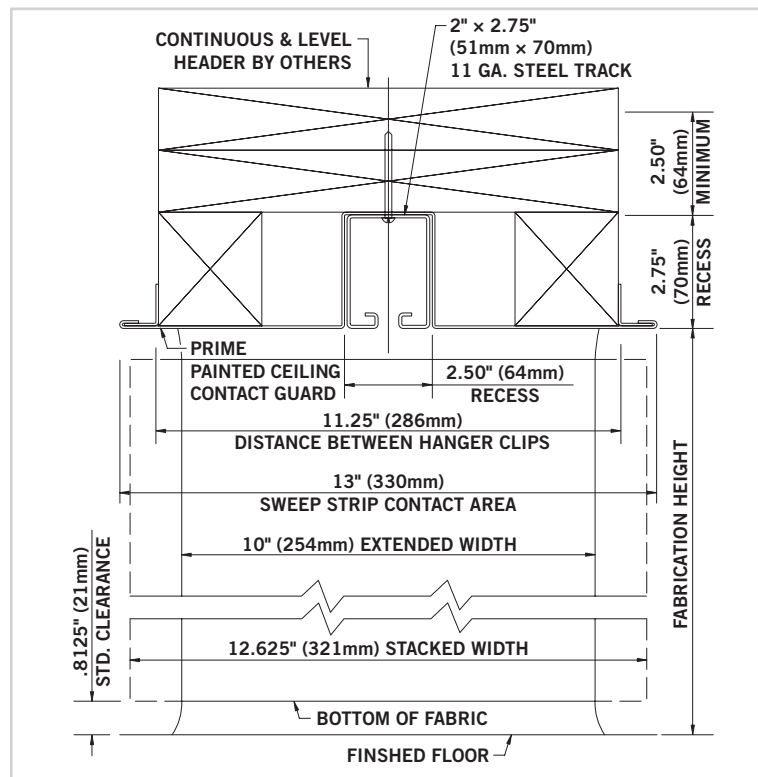

NOTE: Electrical operation required for openings over 400 sq ft (37.2 sq m) for Soundmaster 8,
360 sq ft (33.444 sq m) for Soundmaster 12, and 730 sq ft (67.89 sq m) for Modernfold 1200.

SOUNDMASTER® & MODERNFOLD® TECHNICAL DATA — HEAD DETAILS

Head Detail with #7 Chain Guide Track — for Soundmaster Openings over 360 sq ft (33.4 sq m) — for Modernfold Openings over 730 sq ft (66.9 sq m)

Soundmaster 12 & Modernfold 1200 #7 Track Electrically Operated

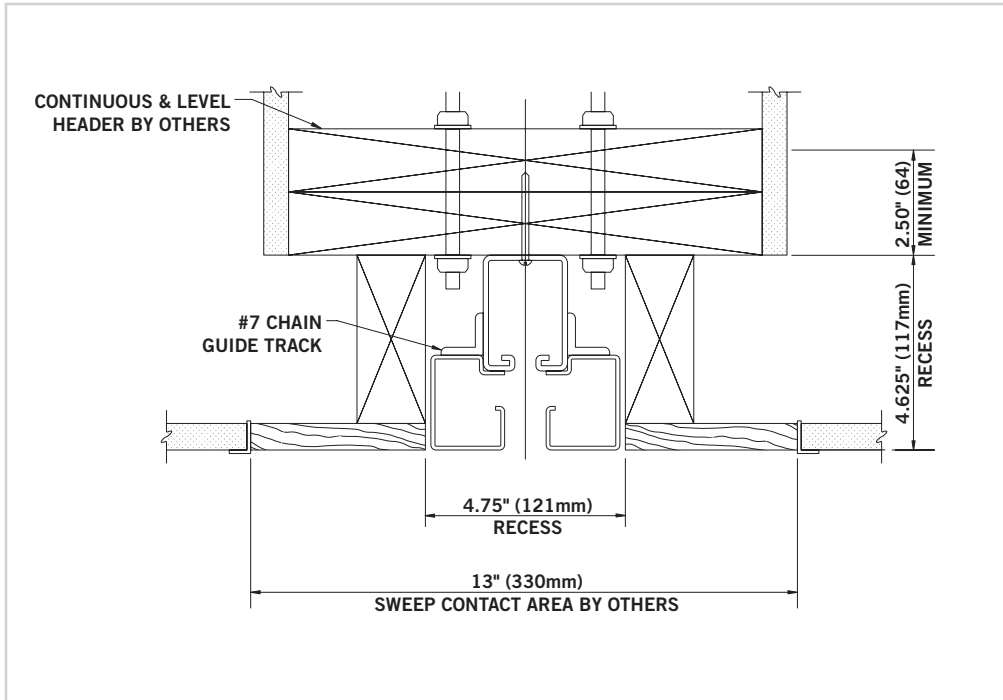

SOUNDMASTER® & MODERNFOLD® TECHNICAL DATA

ACCESSORY TRACK SWITCHES, MEETING POSTS

Glide Switch

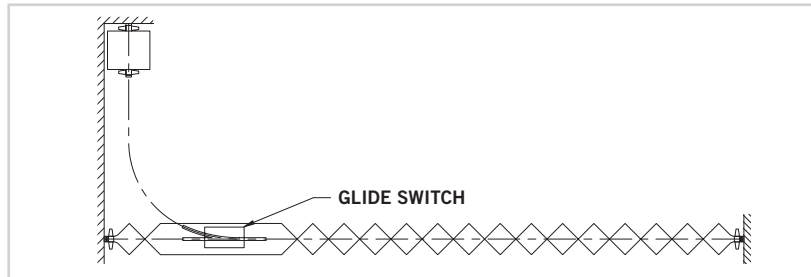

Cross Track Switch

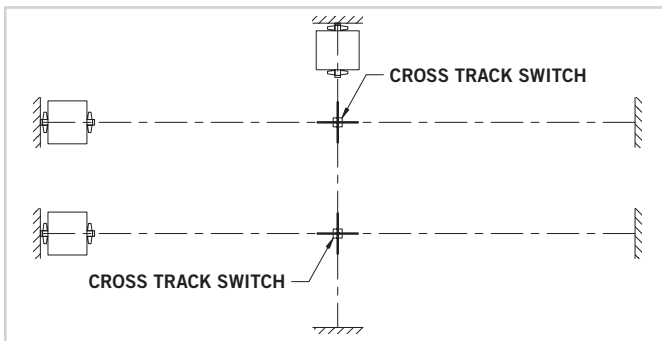

Curved Track

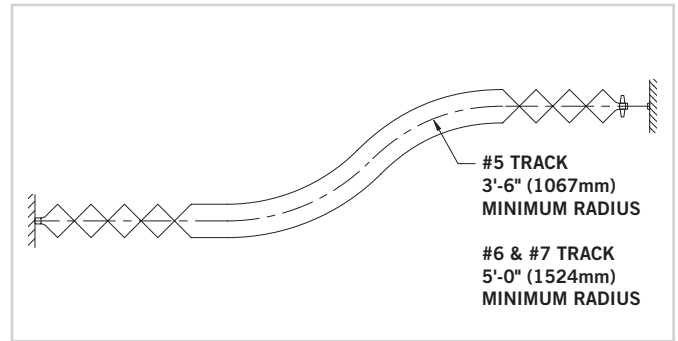

“L” Post

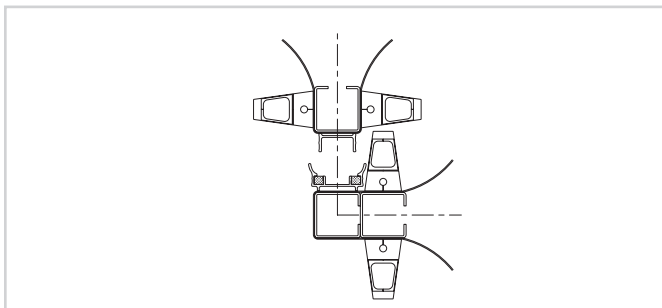

Free Rolling “T” Post

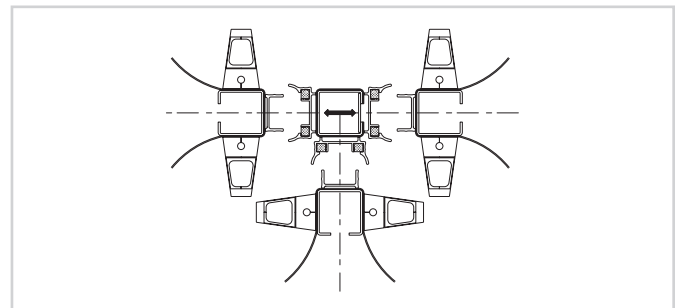

Intermediate Post

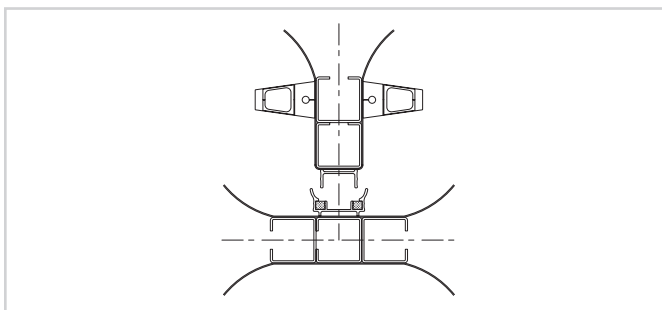

Free Rolling “X” Post

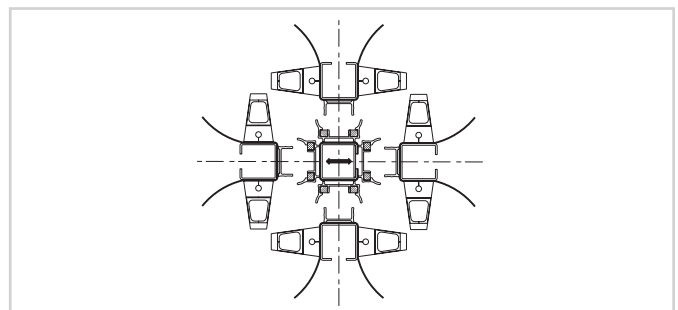

NOTE: Handles meeting at perpendicular intersections are at staggered heights to prevent interference.



DORMA Group North America

Leaders in Architectural Opening Solutions

Modernfold, Inc.
215 West New Road
Greenfield, IN 46140

Toll Free: 800.869.9685
email: info@modernfold.com
www.modernfold.com

A DORMA Group Company
www.dorma-usa.com

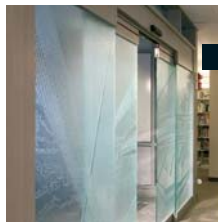

DORMA Entrance Systems[™]

Pedestrian Flow, Safety & Security

DORMA Automatics • Crane Revolving Doors • Carolina Door Controls
Providing entrance systems that meet or exceed industry standards while maintaining architectural appeal.



DORMA Architectural Hardware

Providing Safety & Security Around the Door

Offering a complete line of door controls, locks, exit devices, and electronic access control hardware.



DORMA Glas

Elegance, Versatility & Beauty

Delivering modern style and reliable performance with accessories and systems for tempered glass entrances.